

EPC - FUSION BONDED EPOXY COATED CAST IRON HUBLESS BRANCH TEE 88°



COMPLY WITH EN877:2010 01

COATING CHARACTERISTIC
Fittings:

Epoxy fittings inside and outside: Fusion bonded epoxy coating.

Coating Thickness: Min- 240µm

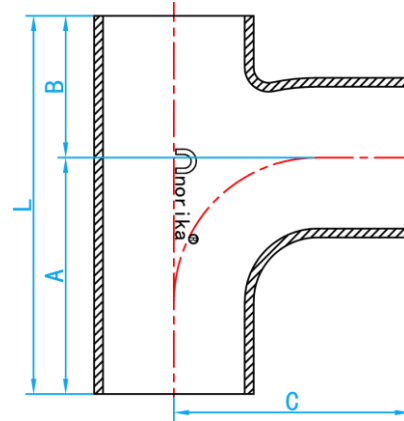

CROSS SECTIONAL VIEW

*Availability upon request

DIMENSIONS

SKU	DN (mm)	A (mm)	B (mm)	L (mm)	C (mm)	WEIGHT (kg)
HUBEET050	50X50	79	66	145	80	1.08
HUBERT08050	75X50	95	85	180	90	1.60
HUBEET080	75X75	95	85	180	90	1.61
HUBERT10050	100X50	94	76	170	105	2.00
HUBERT10080	100X75	105	90	195	110	2.65
HUBEET100	100X100	115	105	220	120	2.60
HUBERT12550	125X50*	98	82	180	120	3.00
HUBERT12580	125X75*	110	94	205	125	3.40
HUBERT125100	125X100*	125	110	235	130	4.00
HUBERT150050	150X50	100	100	200	140	3.78
HUBERT150080	150X75	110	110	220	145	5.00
HUBERT150100	150X100	130	115	245	145	4.95
HUBERT150125	150X125*	147	128	275	150	6.20
HUBEET150	150X150	158	142	300	155	5.86
HUBERT200100	200X100	144	126	270	175	7.40
HUBERT200150	200X150	173	152	325	185	9.00
HUBEET200	200X200	202	178	380	195	12.80
HUBERT250100	250X100	165	147	312	210	13.30
HUBERT250150	250X150	195	160	355	230	19.30
HUBERT250200	250X200	205	200	405	240	21.00
HUBEET250	250X250	250	220	470	240	24.50
HUBEET300	300X300	300	266	566	300	38.00

Notes: The tolerance for Weight is $\pm 10\%$.